

CS7010

Greener, cleaner and smarter

- hybrid & battery drive combination sweeper-scrubber



The CS7010 Hybrid and ePower combination sweeper

Suitable for warehouses, manufacturing plants, stadium, university, parking ramps and lots

- 1** ClearView™ sightlines and automatic speed reduction in turns for safer operation
- 2** High impact-absorbing polymer body panels won't dent, corrode or damage facility
- 3** Hybrid Drive backup battery power adds user convenience to drive to refueling station
- 4** High-capacity 7 ft³ (198 liter) front dry sweeper debris hopper with high-lift system
- 5** High performance Donaldson PowerCore® nanofiber filter with variable-frequency shaker
- 6** Heavy-gauge industrial steel unibody frame
- 7** Available with patented DustGuard™ airborne dust suppression technology
- 8** Standard dual side brooms sweep entire squeegee path to minimize fouling
- 9** Seat-accessible hopper safety prop rod



eeper-scrubbers

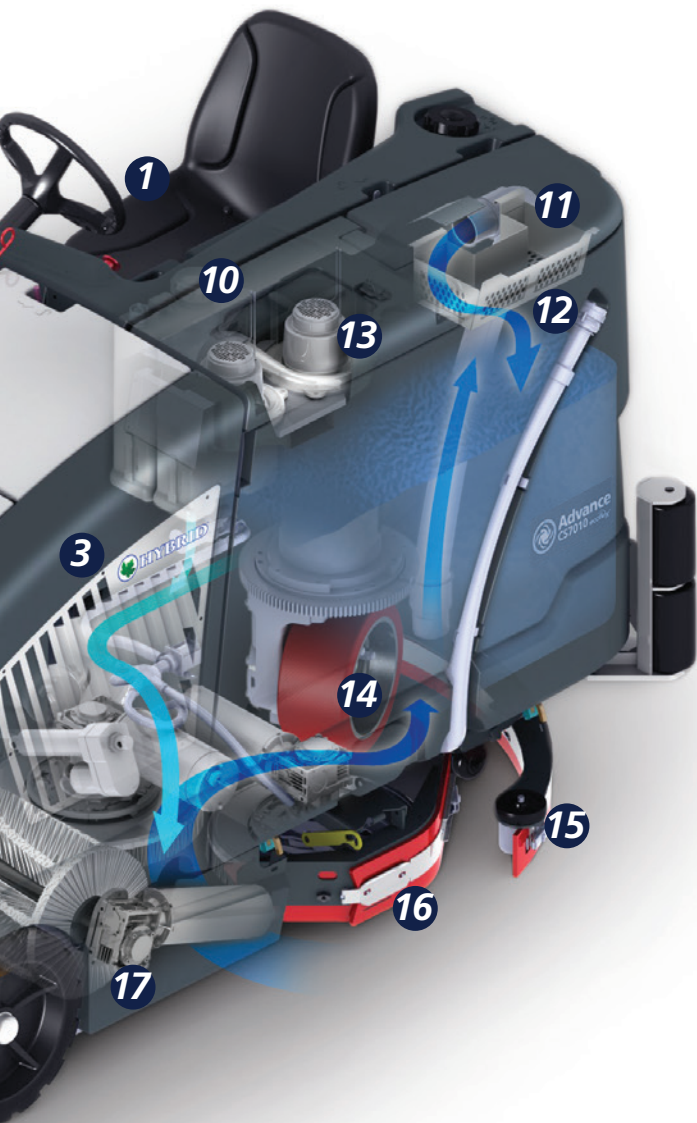

- 10** *Optional dual-tank EcoFlex™ System provides the most flexible cleaning solution for industrial applications*
- 11** *Tools-free tilt-out/lift-off recovery tank with integrated SmartFlow™*
- 12** *High-capacity 75 gallon (285 liter) corrosion-proof solution and recovery tanks*
- 13** *Powerful dual vacuum motors deliver high waterlift and airflow to ensure a safe, dry floor*
- 14** *SmartFlow technology decreases water and chemical usage*
- 15** *Patented breakaway squeegee mechanism with tools-free servicing*
- 16** *Disc scrub deck with integrated, powerful edge cleaning capability*
- 17** *Brushes, brooms and squeegee can be replaced without tools*
- 18** *Electronically-controlled electric drives are IP55 rated for easy cleaning and reliable operation*

More effective cleaning

DustGuard™



Patented DustGuard™ is proven to reduce airborne dust generated by side broom sweeping. An ultra fine fog suppresses fugitive dust

EcoFlex™ System



EcoFlex™ System with interchangeable dual detergent cartridges are refillable with your favorite brand of detergents

UltraWeb® Nanofilter

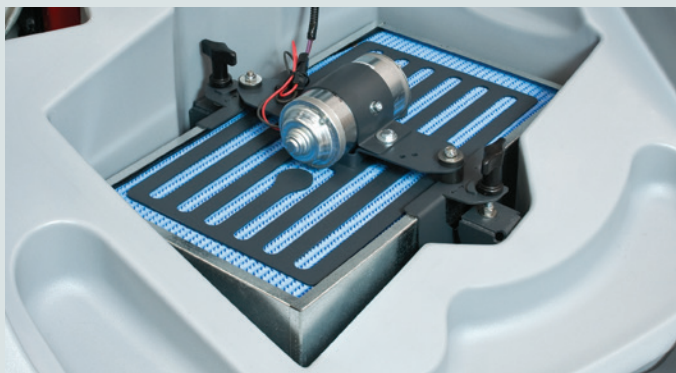

High-capacity Donaldson PowerCore® UltraWe^b® nanofilter synthetic media filter with MERV 13 rating with a variable-frequency shaker. Provides superior dust/dirt holding capacity in a more compact package for longer filter life and improved dust control compared to conventional pleated filters

HYBRID Technology



The CS7010 delivers unparalleled performance, while replacing power-hungry, high-maintenance hydraulic systems with efficient, state-of-the-art Electric Drive technology

Intuitive Control Panel



Intuitive controls with OneTouch™ operation reduce training time, improve productivity and deliver more consistent cleaning results

SmartFlow™



SmartFlow™ adjusts solution flow with the machine's speed, using water and chemicals. Proportionally higher productivity with fewer dump and refill cycles per tankful

Simpler cleaning

Pivoting Scrub Deck

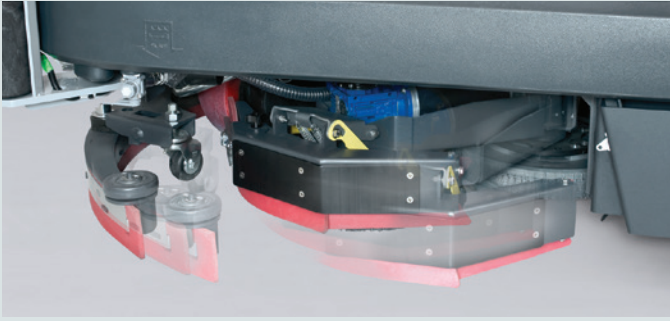

Retractable 4 inch (10 cm) offset disc deck enhances edge scrubbing and resists damage from accidental impact

MaxAccess™

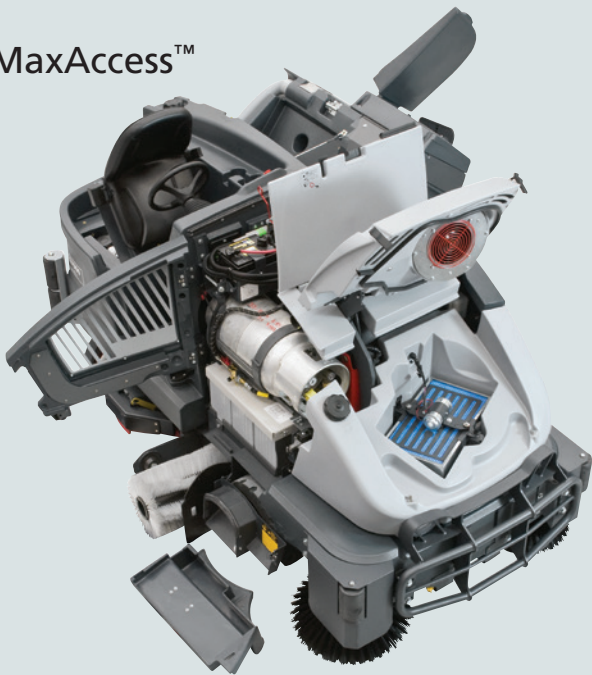

We designed the CS7010 to provide quick access to all vital systems for easier inspection and maintenance

Safer cleaning

Speed reduction



Automatic speed reduction in turns for improved safety and reduced risk of impact damage

Ergonomic operator compartment



The CS7010 has a fully adjustable seat and tilt steering



Kubota® Industrial Engine

- Rugged industrial engine design offering superior operating life
- Best in industry quiet operation
- Gear-driven valve train eliminates timing belts or chains, improving reliability and reducing maintenance costs

Technical Specifications

Models	CS7010 Battery	CS7010 LPG/Gas Hybrid	CS7010 Diesel Hybrid
Configuration	Independent front dry sweeping w/dust control and rear scrubbing functions Electronically controlled electric drives for all sweeping and scrubbing functions Electrically driven hydraulic power unit for hopper raise/lower functions		
Sweeping System			
Sweeping Path w/Dual Side Brooms	61 in (154 cm) - Squeegee path width is fully swept		
Main Broom	36 in (90 cm) x 12.2 in (31 cm)		
Sweeping Coverage Rate Per Hour	146,400 ft ² (13,600 m ²)		
Dust Control System	115 ft ² (10.7 m ²) Donaldson high-capacity PowerCore® UltraWeb® filter w/synthetic media. Variable frequency automatic filter shaker		
Hopper Dump Height (Max.)	60 in (152 cm)		
Hopper Capacity	7 ft ³ (198 L) 300 lb (136 kg)		
DustGuard™ Tank Capacity ¹	29 gal (110 L)		
Scrubbing and Recovery Systems			
Scrubbing Path and Brushes	48 in (122 cm) - 3 x 17 in (43 cm) disc		
Scrubbing Coverage Rate Per Hour	118,600 ft ² (11,000 m ²)		
Scrub Pressure	Three scrub pressure settings up to 400 lb (182 kg) of down force at maximum setting		
Recovery/Solution Tank Capacity	75 gal (285 L) each		
Recovery Vacuum	Dual vac fan motors capable of 65 in (165 cm) waterlift		
Power and Propulsion Systems			
Power System	Battery: 36 V/770 Ah	Kubota WG972: 3 cyl., 0.96 L 30 hp (22.0 kW)	Kubota D1305 : 3 cyl., 1.26 L 24.8 hp (18.5 kW)
Propulsion System	Variable speed brushless A/C drive		
Propel Speed (Variable) Transport Sweeping/Scrubbing	5.5 mph (8.9 km/h) 3.5 mph (5.6 km/h) w/override capability		
Operational Run Time Sweeping/Scrubbing ²	5.4 hrs. w/770 Ah battery	LPG - 5.5 hrs. w/32 lb (14.5 kg) tank Gas - 5.9 hrs. w/9.2 gal (35 L) tank	15 hrs. w/9.2 gal (35 L) tank
Gradeability Transport @ Gross Weight Scrubbing/Sweeping	21% (12 deg.) 17.6% (10 deg.)		
Dimensions/Weight/Sound/Environmental			
Length	103 in (262 cm)		
Width	48 in (122 cm)		
Height	[59 in (150 cm)] [82 in (208 cm) std. overhead guard] [79 in (201 cm) low clearance overhead guard]		
Minimum Aisle Turn	104 in (264 cm)		
Weight : GVW Empty	5,716 lb (2,593 kg) 4,682 lb (2,124 kg)	4,676 lb (2,121 kg) 3,636 lb (1,649 kg)	4,537 lb (2,058 kg) 3,511 lb (1,593 kg)
Sound Level (IEC60335-2-72)	72 dB A	82 dB A	81 dB A
Water Ingression	All electric drive motors and actuators rated IP55 for water washdown		

Specifications are subject to change without notice.



Reach a new standard of cleaning power.
Visit <http://www.nilfisk.us> or contact your
Advance sales representative to learn more.
©2019 Nilfisk, Inc. Form L3235A 01-03-19



¹ DustGuard™ optional

² Measured run time using low scrubbing and sweeping mode at normal operating speeds on smooth floors (actual results will be application dependent)

CS7010 models shown in photos may feature optional accessories

Nilfisk, Inc.

9435 Winnetka Avenue North
Brooklyn Park, MN 55445
www.nilfisk.us
Phone 800-214-7700
Fax 800-989-6566

Nilfisk Canada Co.

240 Superior Boulevard
Mississauga, Ontario, Canada L5T 2L2
www.nilfisk-advance.ca
Phone 800-668-8400
Fax 800-263-5111

